



Tech Notes

iFi audio hip-dac

Beauty that is not skin deep



Introducing the smallest balanced DAC around

Here at iFi audio, we've already created a number of small portable devices. As much as we love them all, we like to continue to push the envelope. To bring to you a device that's smaller, lighter and simpler than ever before; the iFi audio hip-dac.

The hip-dac weighs only 125g and measures 10.2 x 7 x 1.4 cm, which makes it a sleek, easy to carry, ultra-portable solution, perfect for consumers after a pocket DAC/amp loaded with cutting-edge technology and features.

Balanced at a revolutionary price point

One of the hip-dac's key features is its balanced circuit design. AMR/iFi audio prides itself on trickle-down technology. The ZEN was the first series to benefit from the flagship balanced Pro machines, but we pushed further and had this topology implemented in our hip-dac.

Why 4.4mm?

The XLR is good, but too large for a portable chassis. The mini XLR is not popular. The 3.5 TRRS is not an industry standard. And for not so well-designed amplifiers, plugging in a TRS 3.5 will burn out the 3.5TRRS balanced amp! The 2.5mm socket is weak and not too adept at withstanding daily use.

The answer is the 4.4mm socket. It is compact, a growing industry standard and built well. Hence, we picked the 4.4mm as the de facto portable balanced connection. And not only for headphone output, as the ZEN series uses the 4.4mm for balanced line output too.

Truly native heart

Proper digital to analogue conversion is a must. Here, the Burr-Brown DAC has what it takes. Not only to achieve great sound, but also to allow for truly native DSD and PCM data streams. When it comes to D/A converter chips, we go all out. Our hip-dac's heart is the very same as in many of our pricier products – a custom-programmed Texas Instruments Burr-Brown DSD1793. Hip-dac natively supports digital content up to DSD 256/DXD384/PCM384kHz and handles MQA playback on top of that. Simply put, it does pretty much everything one could want from a portable multi-tasker.

Multibit digital engine with AMR Global Master Timing

The hip-dac is very much akin to the micro iDSD Black Label for a perfectly valid reason. Both products are based on the custom-programmed Burr-Brown DSD1793 D/A converter chip.

Burr-Brown MultiBit



The digital section of the hip-dac is drawn from the micro iDSD Black Label. The USB type A OTG/CCK connector offers supreme portability plus dependability and direct connection to Apple CCK/Android OTG.

[Global Master Timing® from AMR.](#)



In the hip-dac, the clock domain naturally covers USB but also synchronizes the MCU (Master Control Unit) to effectively ensure the hip-dac's entire digital functionality is slaved to the GMT clock system. It is global by name and by nature. The above are all reasons why the hip-dac's digital heart is as good as it can be.

Tech Notes

The key components are:

- i. Precision analogue volume control potentiometer;
- ii. iFi audio's proprietary high-performance, low-noise, quad J-Fet OV4627A operational amplifiers;
- iii. Dual-mono power amp IC headphone drivers.

The hip-dac draws upon the existing iFi headphone platform but with the circuitry ratcheted up several notches. Performance is increased, both noise and distortion are lowered and XBass function gains electronic switching.



True Native delivered by the octa-core Transputer Chip

At the heart of the hip-dac is the same Burr-Brown 'True Native' chipset as found in the flagship Pro iDSD. It offers two separate signal pathways for PCM and DSD, the 'best of both formats' as the signal quality remains native.

Choosing the right DAC topology significantly affects the final sound. We loved the dynamics and slam of the multi-bit topology (e.g. the legendary Philips TDA1541A), however with high-definition it (actually there's no true multi-bit DAC chipset available yet) doesn't have the low-level linearity of the Delta-Sigma topology.

For best of both worlds:

- Multi-bit for dynamics and slam (the higher bits of the PCB data);
- Delta-Sigma for the low level linearity (the lower bits of the PCB data);

The DAC chip we picked for hip-dac has:

- Top 6 bits: true multi-bit;
- Lower bits: Delta-Sigma.

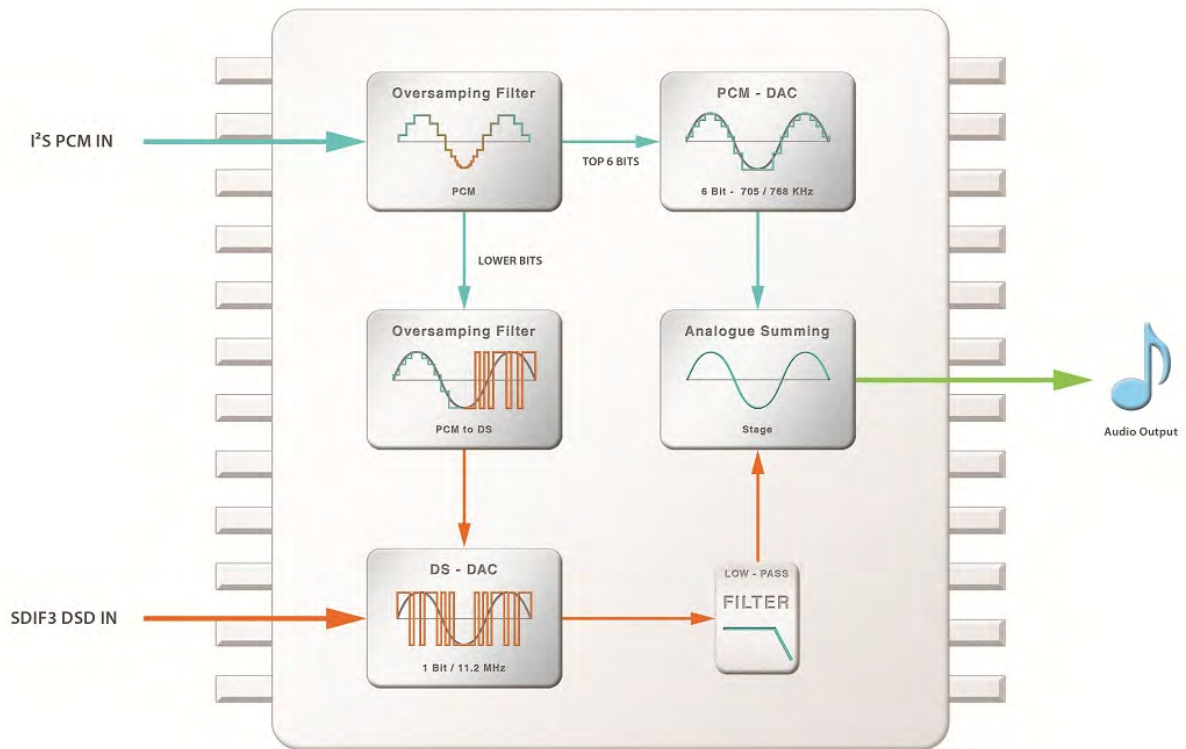

DSD256 is available on Windows via ASIO DSD and with special firmware on OSX, Windows and Linux via DoP DSD

Running alongside the Burr-Brown 'True Native' chipset is the 8-Core XMOS based on our own code, which updates it with our own Star Clocking, just as it was done in the micro iDSD.

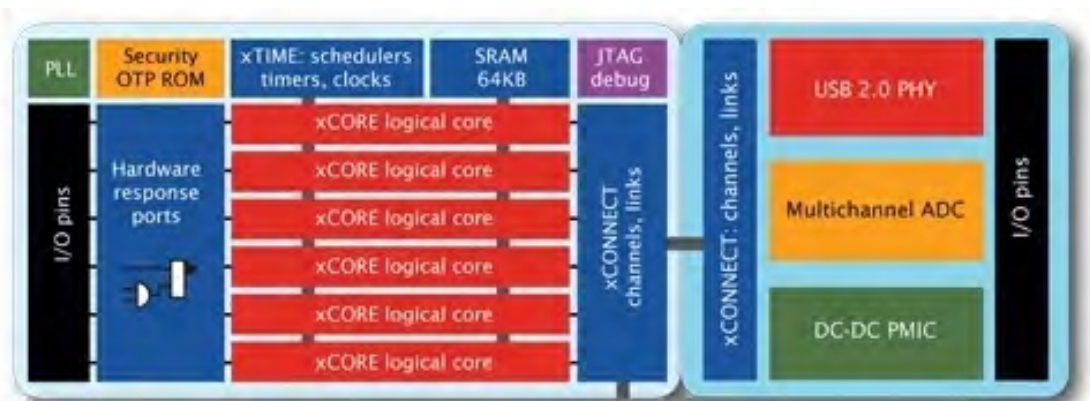

The hip-dac implements Version 4 AMR XMOS platform and uses the latest generation 8-Core 500MIPS XMOS1 transputer derived main processor. These processors are quite unique in their architecture and based on a technology once considered to revolutionize computing, the INMOS Transputer.



Tech Notes

From Inmos to XMOS

The transputer (Trans – Com – Puter) was a pioneering microprocessor architecture of the 1980's, intended for parallel (multi-core) computing. It was designed among others by David May and produced by Inmos, a semiconductor company based in Bristol, United Kingdom.

For some time in the late 1980's many considered the transputer to be the next great design for the future of computing. While INMOS themselves ultimately faded from the scene, their pioneering parallel computing platform is echoed in every modern PC running Dual or Quad Core CPUs and in any multi-core CPUs found in i.e. smartphones and tablets. XMOS "Transputer" Chips have since found many applications where their unique architecture outperforms both traditional CPUs and FPGA systems, not the least in USB Audio.

What all this means for hip-dac? Its XMOS unlocked 384kHz/32Bit PCM and 11.2MHz single bit DSD sample rates.

DSD 256/MQA



Just about every iFi DAC offers MQA because we always pursue better quality music and as many choices for our customers as possible. Our engineers implemented MQA functionality in hip-dac's firmware, alongside every other format this product can handle. Whatever music type or quality you're into, the hip-dac has you covered.



The new hip-dac sports a dual-mono headphone amplifier with 4.4mm balanced connection. This technology trickled-down from our flagship Pro range (i.e. Pro iCAN) which has a True Differential Balanced circuit.



The hip-dac offers balanced in/out to take full advantage of the growing availability of balanced headphones. Underpinning the exemplary circuitry, the hip-dac uses a precision analogue volume control potentiometer (instead of the standard digital volume control which truncates the dynamic range meaning 'less 'Bits' unless at full volume!). As for the amplification stage, we again, use our OV4627 amplifier chips (4 channel) to deliver exceptional sonic performance on-the-go.

Balanced output amp:

Balanced headphone output is a topology that uses inverse positive/negative electrical paths to deliver equal and opposite audio signals to each side of the headphone driver voice coil.

With this, audio performance is audibly and measurably better due to a doubling of power as well as slew rate; along with reduction of THD distortion and crosstalk compared to standard 'single-ended' headphones it is one of the 'holy grails' when it comes to portable audio.

The main advantages of Balanced over traditional Single-Ended:

- **Drivability** - double the voltage output, can drive bigger and more exotic headphones
- **Crosstalk** – significantly less of 1,000x better in theory but in practice is still much improved in terms of several-fold decibels
- **Interference/noise rejection** – largely cancelled out

Tech Notes

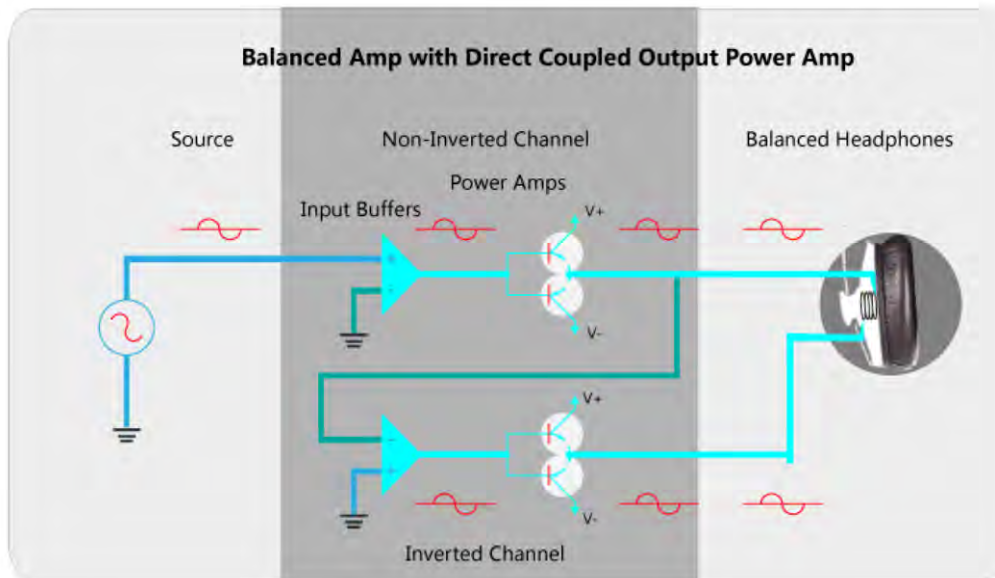

In the Balanced amp topology, the second amplifier doubles both signal levels versus an unbalanced amplifier, which makes this good for power-hungry, less sensitive headphones. A dedicated negative wire per channel makes sure there is no crosstalk between them, which is a plus for regular balanced outputs, but headphones/IEMs finished with TRS jacks are not compatible. This is where the hip-dac also has S-Balanced which makes iFi portable components unique.

S-Balanced (as found in xCAN, xDSD and nano iDSD BL)

The spectrum of headphones is broad. At one end are relatively insensitive and difficult to drive headphones which are suited to the Balanced topology (via 4.4mm socket) as discussed in the previous section.

However, at the other end is the In-Ear-Monitor (IEM) which is typically very sensitive. For this, we have S-Balanced which is our unique circuit topology specially-suited to IEMs (via 3.5mm socket).

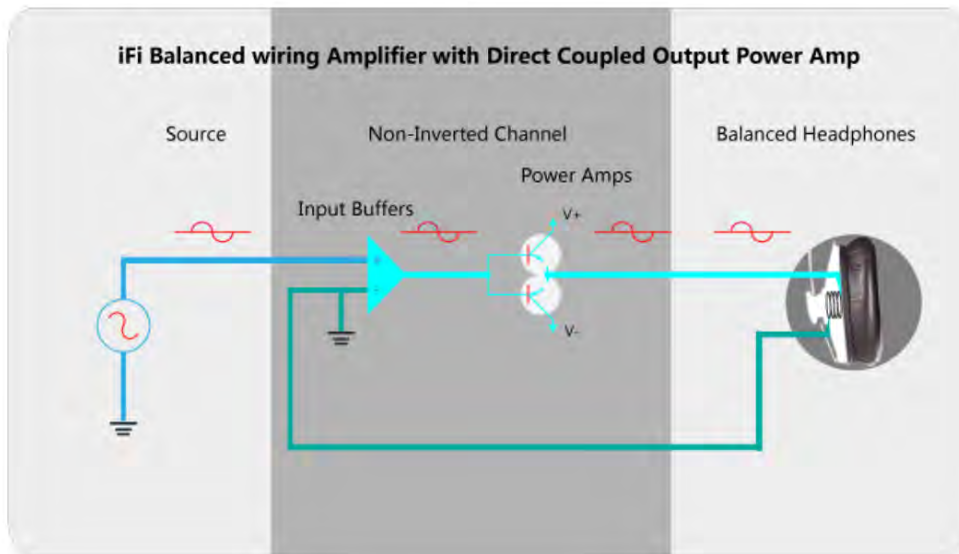

With S-Balanced, no second amplifier is used, neither are extra signal, noise, nor distortion added - perfect for sensitive IEMs. A dedicated negative wire per channel all the way to each channel's amplifier's star-ground makes sure there is no crosstalk between the channels.

Plugging in unbalanced headphones with a TRS connector instead of TRRS will cause zero issues. In fact, this way will cut crosstalk by 50%, compared to using a TRS socket!

S-Balanced on TRS & TRRS headphones

S-Balanced is fully compatible with, and supports balanced wired headphones on TRRS 3.5mm and the 3.5PRO balanced wiring standard maintaining channel separation. This is, after all, the point of S-Balanced.

It can also use 3.5mm TRS connections without issue. We are compatible with Hifiman/3.5PRO/OPPO PM3 in the above on 3.5mm S-Balanced and 2.5mm Balanced equipped products such as A&K/FiiO

S-Balanced delivers the full benefits with lower noise and distortion (and lower output) than other balanced circuitry and is compatible with TRS headphones and headphones with microphones making sure neither amp nor headphone can be damaged.

The key to the S-Balanced advantage is to understand the following:

- A balanced output includes two separate amplifiers
- All else being equal, two amplifiers contribute both noise and distortion



Tech Notes

- Due the laws underpinning this, the output noise of the two balanced amplifiers **MUST** be at least 3dB greater (1.4 times) than that of the single amplifier
- The odd order (unpleasant or disharmonic) distortion of the two amplifiers for the same level on each amplifier summed will also be at least 3dB greater than the single amplifier.

Balanced and then some

To sum up, with Balanced and S-Balanced (along with PowerMatch and XBass) all in one chassis in the hip-dac, we have game-changing tech for the modern portable audiophile. Balanced and more, maximum enjoyment for all headphones.

PowerMatch

The amp stage features switchable gain, which we call PowerMatch. This option matches the level of drive to the load presented by the headphones, by adjusting input sensitivity and signal strength. With less sensitive headphones such as large cans, put PowerMatch at its higher setting for best performance and vice versa for IEMs.

XBass



XBass is primarily for open-back headphones or just those tracks that 'miss that bit of bass'. By now, our customers are familiar with the Analogue Signal Processing circuit that was developed in-house for our own use.

Premium audiophile parts

TDK high stability COG surface mounted capacitors - COG dielectric close to Teflon in key areas that affect the smoothest sonics.



As you can see, the hip-dac really is one of those products that looks spectacular on the outside, and sounds absolutely wonderful because of what is inside.

hip dac

For further information, please contact: Victoria Pickles
press@ifi-audio.com / +44(0) 1704 227 204

About iFi

iFi audio is part of AGL and is headquartered in Southport, UK. It owns the hifi brand Abbingdon Music Research (AMR). They respectively design and manufacture portable and desktop 'ultra-fidelity' audio products and high-end audio 'home-based' components. The combined in-house hardware and software development team enables iFi audio and AMR to bring to market advanced audio products.